

EFFECTIVE:
28-MAR-19

DIMENSION PRINT
WORLD MOTOR AUTO DUTY

PRINT:
08-1186

SUPERSEDES:
NEW

FRAME: 254U, 256U
BASIC TYPE: JDE

SHEET:
1 OF 1

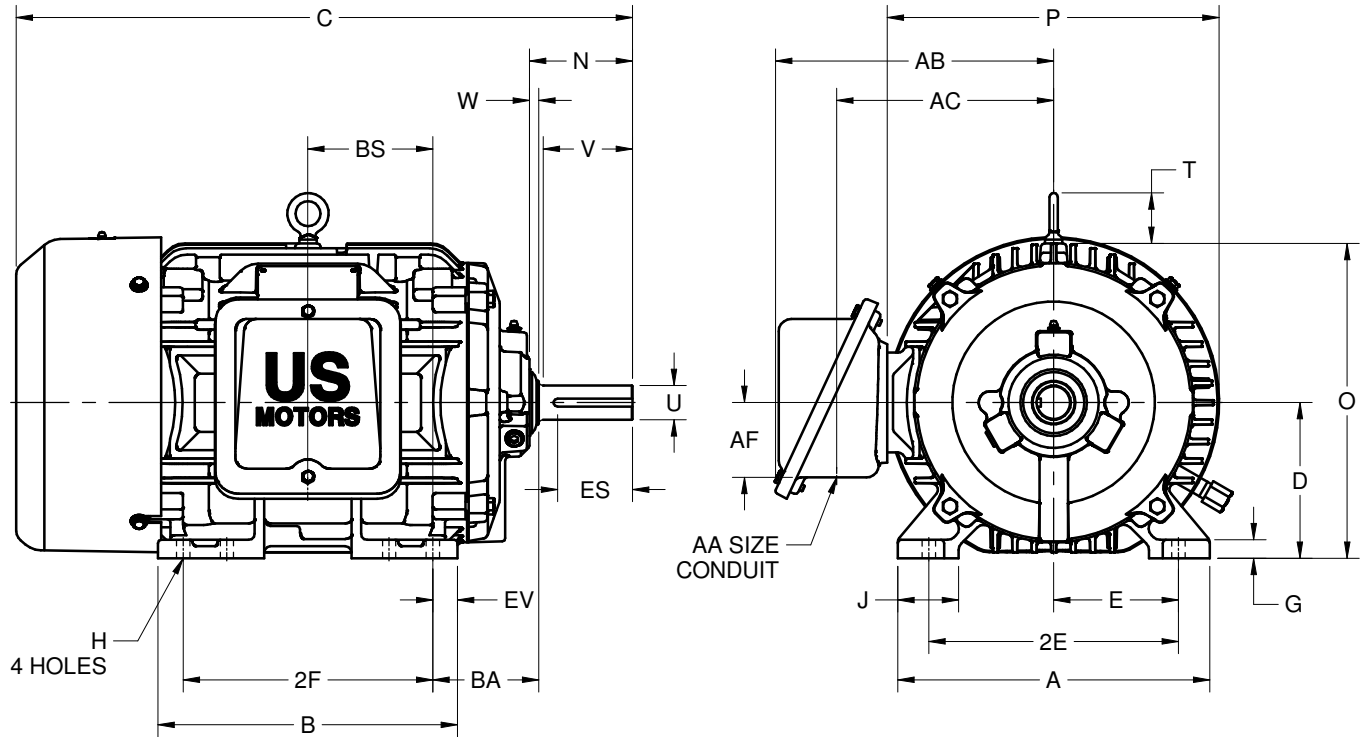

ALL DIMENSIONS ARE IN INCHES AND MILLIMETERS

UNITS	A	B	C	D -.06	E	2E ±.03	G	H +.05	J	K	N	O	P ²
IN	12.50	12.00	24.69	6.25	5.00	10.00	.75	.53	2.44	4.25	4.13	12.63	13.47
MM	318	305	627	159	127	254	19	13	62	108	105	320	342

UNITS	T	U -.001	V MIN	W	AA	AB	AC	AF	BA	BS	EV	ES MIN	SQ KEY
IN	2.03	1.375	3.75	.38	1-1/4 NPT	11.13	8.66	3.00	4.25	5.00	1.00	2.75	.313
MM	52	34.93	95	10		283	220	76	108	127	25	70	7.95

FRAME	UNITS	2F ±.03
254U	IN	8.25
	MM	210
256U	IN	10.00
	MM	254

1. DIMENSIONS MAY VARY .25" DUE TO CASTING AND/OR FABRICATION VARIATIONS
2. LARGEST MOTOR WIDTH
3. STANDARD ASSEMBLY POSITION F-1 IS SHOWN. F-2 IS PROVIDED WHEN SPECIFIED. CONDUIT OPENING MAY BE LOCATED IN STEPS OF 90° REGARDLESS OF THE LOCATION
4. TOLERANCES ARE SHOWN IN INCHES ONLY

08-1186/-

Nidec Motor Corporation
St. Louis, Missouri

INFORMATION DISCLOSED ON THIS DOCUMENT IS CONSIDERED PROPRIETARY AND SHALL NOT BE REPRODUCED OR DISCLOSED WITHOUT WRITTEN CONSENT OF NIDEC MOTOR CORPORATION



ISSUED BY
I. GONZALEZ
APPROVED BY
C. CORONADO

IHP_DP_NMCA (MAR-2011) SOLIDEDGE